

## CONTROL OF ELECTRIC VEHICLE USING DIGITAL SIGNAL CONTROLLER

Ashraf Salah El Din Zein El Din,  
Adel Shebl Abdel Ghafar  
Professors in Faculty of Engineering,  
Minoufiya University,  
Gamal Abdel Naser Street,  
Shebin El Kom, Egypt.  
e-mail: ashrafzeineldin2002@yahoo.com

Zeyad Mohamed Mohamed Rezk  
Electrical Engineer in Petroleum Gas  
Company,  
Quessena City, Egypt.  
e-mail: [zevad\\_rezk@yahoo.com](mailto:zevad_rezk@yahoo.com)

### ABSTRACT

*Electric vehicles are the cars of the future as they are high efficient, produces no local pollution, are silent, and can be used for power regulation by the grid operator. The model of an electric vehicle is very complex as it contains many different components, e.g. transmission, electric machine, power electronics and battery. Each component needs to be modeled properly in order to prevent wrong conclusions. Therefore, the controller should be designed to make the system robust and adaptive, improving the system on both dynamic and steady state performances. The prime objective of this research was to develop a prototype controller which can replace the original one mounted on Medical Appliances and Packages Company (MAPC's) wheelchair. Thus, a control unit is designed and interfaced to the motor chair in order to control the speed and direction of electric vehicle. The performance of electric vehicle has been studied analytically and experimentally. The comparison between the analytical results and the experiential results are comparable. The performance of the proposed control unit is highly effective and low cost price which may be used in a wide range in industry.*

**Keywords:** Electric Vehicle, Electric Wheelchair, Proportional Integral, Digital signal controller.

### 1. INTRODUCTION

The major components of an electric vehicle system are the motor, controller, power supply, charger and drive train [1]. The controller is the heart of an electric vehicle, and it is the key for the realization of a high-performance electric vehicle with an optimal balance of maximum speed, acceleration performance, and traveling range per battery charge. Control of Electric Vehicle (EV) is not a simple task in that operation of an EV is essentially time-variant (e.g., the operation parameters of EV and the road conditions are always varying). Therefore, the controller should be designed to make the system robust and adaptive, improving the system on both dynamic and steady state performances. Another factor that makes the control of EV unique is that EV's are really "energy-management" machines [2], [3]. Currently, the major limiting factor for the wide-spread use of EV's is the short running distance per battery charge. Hence, beside controlling the performance of the vehicle (e.g., smooth driving for comfortable riding), significant efforts have to be paid to the energy management of the batteries mounted on the vehicle. However, from the viewpoint of electric and control engineering, EV's are advantageous over traditional vehicles with internal combustion engines.

A model for a fuel cell hydrogen vehicle driven by a Brushless DC Motor (BLDCM) where a two leg directly coupled Interleaved Boost Converter (IBC) is used to power the motor from the fuel cell through a three-phase inverter. The studied system of the Fuel-Cell Vehicle (FCV) is designed and simulated using the commercial PSIM9 software. The ripple contents of current and voltage at the fuel cell output

and the motor input are estimated [4]. With the development of high computing capability microprocessors, such as Digital Signal Controller(DSC), it is possible to perform complex control on the electric vehicle to achieve optimal performance[5]. This paper will mainly focus on designing a low-cost controller for a Two-motor (BEV) battery-powered electric vehicle using DSC to achieve robust controller characteristics in electric powerchair applications. A powerchair user might also have special seating or arm and leg rest requirements that are better served by a powerchair than a mobility scooter. The technology involved in electric wheelchairs is similar to that of mobility scooters and some powerchair manufacturers are offering models that look more like a mobility scooter than a traditional wheelchair. The battery charger will usually plug into the powerchair control unit whilst the batteries are attached. This means that the user doesn't have to worry about lifting or refitting batteries[6].

**2. A MODEL OF AN ELECTRIC VEHICLE**

Figure 1 demonstrates a system model for an electric vehicle. The controller is the heart of an electric vehicle, and it is the key for the realization of a high-performance electric vehicle with an optimal balance of maximum speed, acceleration performance, and traveling range per battery charge[7].

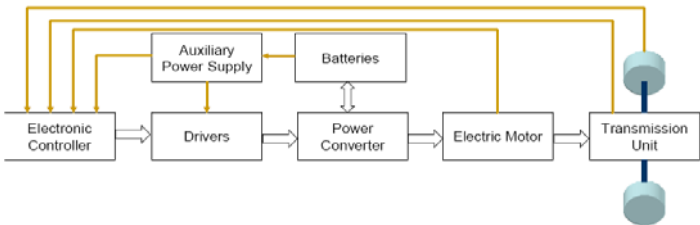

Figure 1. Major Component in an Electric Vehicle

**3. SYSTEM DESCRIPTION**

A schematic diagram for the proposed electric vehicle is shown in Figure 2. It consists of Personal Computer, 56F8013 DSC, 24 Volt. D-C Battery, two Permanent Magnets DC motor, and Motor controller. The practical system is selected as an Electric Wheelchairs as shown in Figure 3, the controller acts as the command center for the wheelchair, it is responsible for the speed and the maintenance of straight line propelling and turning control when the chair is in use. The controller derives its energy from two rechargeable batteries. This controller gives the individual the ability to move the chair forward, backward, left and right to make any variation of turns up to 360 degrees.

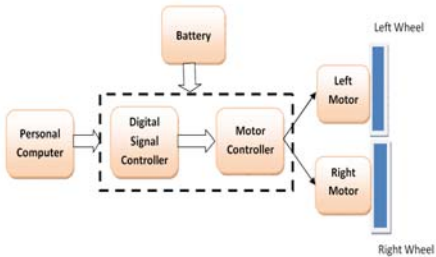

Figure 2. A schematic diagram for the proposed electric vehicle



Figure 3. A practical system

The original controller however faced many problems as it cannot operate the wheelchair motors continuously during climbing roads and it had to be replaced.

**4. THE PRINTED PROPOSED WHEELCHAIR CONTROLLER**

A high-power H-bridge board has been chosen to replace the original controller as shown in Figure 4. The HIP4081A has 4 inputs, ALI, BLI, AHI and BHI, which control the gate outputs of the H-Bridge. The DIS, "Disable," pin disables gate drive to all H-Bridge MOSFETs regardless of the command states of the input pins above. The state of the bias voltage, VDD, also can disable all gate

drive as discussed in the introduction. With external pull-ups on the high input terminals, AHI and BHI, the bridge can be totally controlled using only the lower input control pins, ALI and BLI, which can greatly simplify the external control circuitry needed to control the HIP4081A.

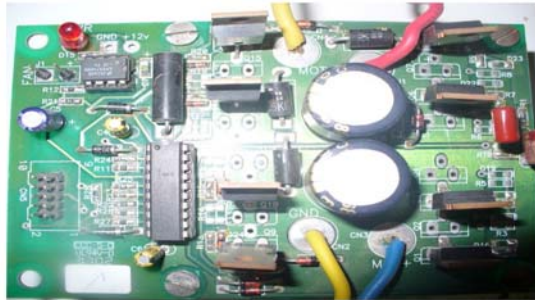

Figure 4. A novel controller for wheelchair motors

### 5. MODELLING OF A PROPOSED SYSTEM

The simulation of a proposed system is performed with MATLAB Simulink, produced by Mathworks (R2009a) and the block diagram is shown in Figure 5

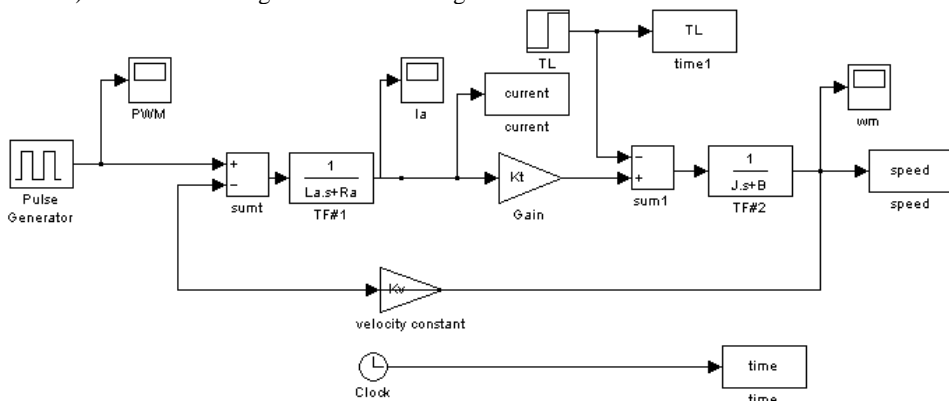
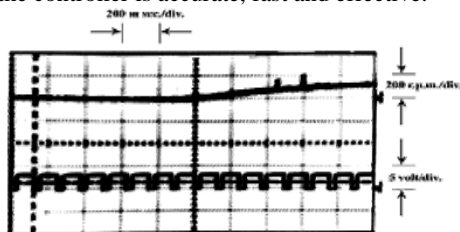

Figure 5. A schematic diagram of a proposed system in MATLAB/SIMULINK

### 6. SIMULATION AND EXPERIMENTAL RESULTS

A sample of an Experimental and simulation results of electric powered chairs performance of electric vehicle during both transient and steady state periods at duty cycle =75% is shown in Figure 6a,b. The ripples shown in speed are due to the controller and the fluctuation of speed is accepted. It can be observed that the performance of motor speed of both simulation and experimental is comparable and the controller is accurate, fast and effective.



Experimental Results

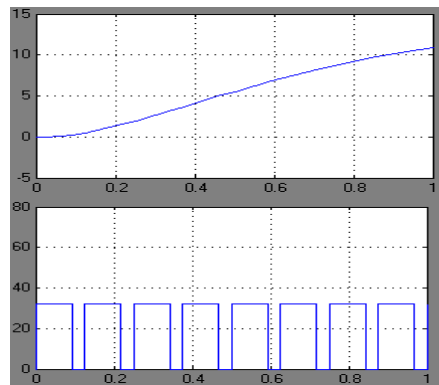

Simulation Results

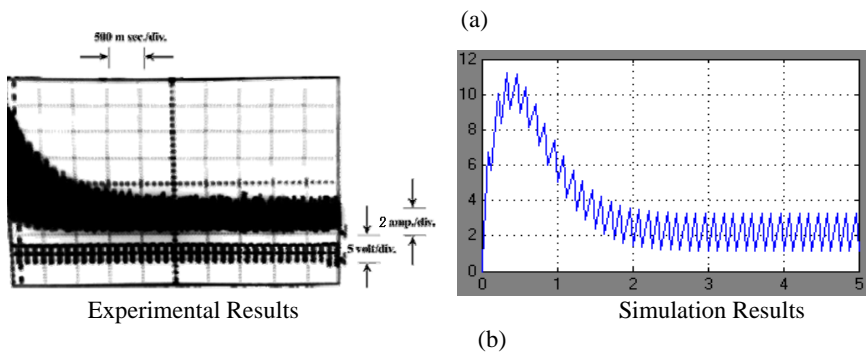

Figure 6. Motor performance of electric vehicle at duty cycle =75%  
 (a) Channel (1): Motor speed (rad./sec.) and Channel (2): Pulses fed to Mosfet driver  
 (b) Channel (1): Motor current (Amp) and Channel (2): Pulses fed to Mosfet driver

## 7.CONCLUSION

In this paper, the wheelchair prototype controller is designed and tested to demonstrate the first steps toward a commercially wheelchair controller, non expensive controller that can be added to a normal power wheelchair. One of the factors that differentiate this controller with the previous attempts is the use of digital signal controller to give the advantage of a DSP and the functionality of a microcontroller with a flexible set of peripherals to create an extremely cost and effective solution because of its low cost configuration flexibility and impact program code. The other import difference between this controller and other design is the use a high power H-bridge circuit; this will allow the system to be lighter, energy efficient, more portable and inexpensive. The actual hardware has been built and tested using PWM (pulse width modulation) pulses as input with different duty cycles and the result shown the prototype controller is robust and reliable. The performance of electric vehicle has been studied analytically and experimentally. The comparison between the analytical results and the experiential results are comparable. The performance of the proposed control unit is highly effective and low cost price which may be used in a wide range in industry. From these results, it is clear that the proposed system is suitable for wheelchair giving accurate and efficient control.

## 8. REFERENCES

- [1] J.Wry , "Electric Vehicle Technology Explained". John Wiley & Sons, Ltd.,ISBN 0-470-85163-5, UK, pp. 183 – 195, 2003
- [2] Y.Cheng,, J.Van Mierlo, P.Van den Bossche, "Energy Sources Control and Management in Hybrid Electric Vehicles". Proc. 12th Int. Power Electronics and Motion Control Conf., Portoroz, Slovenia, Aug. 2006, pp. 524 – 530, 2006
- [3] A.S.Zein El Din, "Closed Loop Control of Electric Vehicle", TMT2009, Hammamet, Tunisia, pp.373-376, 16-21 October 2009
- [4] M. Abdel-Salam, A. Ahmed and A. Elnozahy, "Modeling and Simulation of Fuel Cell Electric Vehicles", 15th International Middle East Power Systems Conference(MEPCON'12), Alexandria, Egypt, December 2012.
- [5] Z.M.Rezk, A.S.Zein El Din, A.S.Abdel-Elghafar, "Automatic Control Applications in An Electric Vehicle", Thesis for Doctor of Philosophy degree in Electrical Engineering, Faculty of Engineering, Minoufiya University, Egypt, May. 2012.
- [6] <http://www.disabled-world.com/assistivedevices/mobility/wheelchairs/> , 2012
- [7] Perujo, A. and Ciuffo, B., "The introduction of electric vehicles in the private fleet: potential impact on the electric supply system and on the environment. A case study for the Province of Milan, Italy" Energy Policy, Vol. 38, pp. 4549-4561., 2010

## 9.SYMBOLS OF MOTOR

La: Armature Inductance = 0.354 H  
 Ra: Armature Resistance = 1.77 ohm  
 Kv: e.m.f. Constant = 1.445

Kt: Torque Constant =1.445 ;  
 J: Moment of Inertia= 0.8 n.m/rad/sec<sup>2</sup>;  
 B: Friction Constant = 0.02 n.m/rad/sec.