

PREPARATION, GROWTH, AND MICROSTRUCTURAL PROPERTIES OF Cr DOPED ZnMgO THIN FILMS

Lütfi Arda

Bahcesehir University, Faculty of Engineering and Natural Science,
Besiktas, 34349, Istanbul, Turkey

Mehmet Can Alphan

Bahcesehir University, Faculty of Engineering and Natural Science,
Besiktas, 34349, Istanbul, Turkey

Cihat Boyraz

Marmara University, Faculty of Technology, Department of Mechanical Engineering,
34722 Goztepe, Istanbul, Turkey

Doğan Akcan

Bahcesehir University, Faculty of Engineering and Natural Science,
Besiktas, 34349, Istanbul, Turkey

ABSTRACT

Preparation, growth, and structural properties of Cr doped ZnMgO thin films were investigated. $Zn_{0.94}Mg_{0.05}Cr_{0.01}O$ solutions were prepared by sol-gel technique. $Zn_{0.94-x}Mg_{0.05}Cr_{0.01}O$ thin films with different thickness were produced on glass substrate dipping prepared solution by using sol-gel dip coating. Obtained thin films were annealed at 600 °C, were tried to observe the films thickness effect on micstructural properties. The crystallite size and structure of thin films were characterized by X-Ray diffraction (XRD). The surface morphologies and microstructure of all samples were investigated by and Scanning Electron Microscope (SEM)

Keywords: ZnO, Sol-gel, Thin Films

1. INTRODUCTION

ZnO-based semiconductors are quite important for many industrial companies in the world. Their investments and efforts tremendously increase day by day to improve the technology behind film and nano particles production. Recently various techniques for the formation of transition metal-doped ZnO nanostructures and films are reported in literature; such as the microwave heating method, auto combustion method, pulsed laser deposition (PLD), sol-gel method, chemical vapor deposition (CVD), and hydrothermal synthesis. Among these, the sol-gel method is increasing because of its efficient and tolerable growth condition, easy control of doping concentration, low cost and simplicity [1-6].

The aims of the present work are: to prepare the mixed oxides $Zn_{0.94}Mg_{0.05}Cr_{0.01}O$ as thin films by a simple sol-gel process; to investigate the changes in the structure and microstructure of $Zn_{0.94}Mg_{0.05}Cr_{0.01}O$ thin films upon increasing thicknesses.

2. EXPERIMENTAL PART

The $Zn_{0.94}Mg_{0.05}Cr_{0.01}O$ solutions were prepared by using sol-gel technique. Zn acetate dihydrate and Mg 2, 4 pentanedionate and Cr acetate were used as precursor materials. Methanol (CH_3OH) was used as solvent. The details of the preparation of $Zn_{0.94}Mg_{0.05}Cr_{0.01}O$ thin films are available in previous studies [1-6]. The as-prepared thin films were annealed in air at 600°C for 30 min.

XRD scans were recorded using a Rigaku diffractometer with Cu K α radiation. Microstructure properties of prepared samples were observed using scanning electron microscope (SEM) (JEOL, JSM-5910LV).

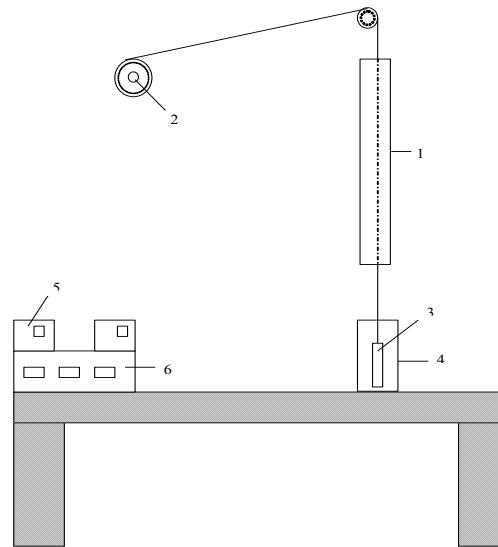

Fig. 1 Sol gel coating system; (1) a furnace, (2) take-up spool, (3) sample, (4) solution tank, (5) electric motor for spool, and (6) furnace controllers.

3. RESULTS AND DISCUSSION

Zn_{0.94}Mg_{0.05}Cr_{0.01}O thin films were deposited on glass substrate by using the sol-gel coating system which is developed in Bahcesehir Univ nano Lab as shown in Fig. 1. The coating properties of Zn_{0.94}Mg_{0.05}Cr_{0.01}O thin films were given in Table 1. As seen in Table 1 the as deposited films with solutions were dried and exposed to heat-treating temperature in 400 °C using in furnace. The coating process of furnace in the sol-gel system has several steps: dipping, drying, burn-out, oxidation and bonding of coating to substrate. Those step depending on time and temperature.

Table 1. Properties of Zn_{0.94}Mg_{0.05}Cr_{0.01}O thin films on glass substrate by sol-gel method

Sample ID	Number of Dipping	T _{Furnace} (°C)	Withdrawal Speed(m/min)	Thickness (nm)
Zn _{0.94} Mg _{0.05} Cr _{0.01} O	10	400	0.65	114
Zn _{0.94} Mg _{0.05} Cr _{0.01} O	20	400	0.65	166
Zn _{0.94} Mg _{0.05} Cr _{0.01} O	30	400	0.65	212
Zn _{0.94} Mg _{0.05} Cr _{0.01} O	40	400	0.65	268
Zn _{0.94} Mg _{0.05} Cr _{0.01} O	50	400	0.65	316

The quality of thin film depends on withdrawal rate, drying, heat treatment condition and sol structure such as chemical composition, purity of precursor solvent catalyst materials and pH value of starting and stabilized solution. Zn_{0.94}Mg_{0.05}Cr_{0.01}O thin films were annealed at 600 °C for 30 min under air using box furnace. The X-ray diffraction of Zn_{0.94}Mg_{0.05}Cr_{0.01}O thin film at 600 °C for 30 min in the air is shown in Fig.2. The reflections correspond to the hexagonal ZnO phase.

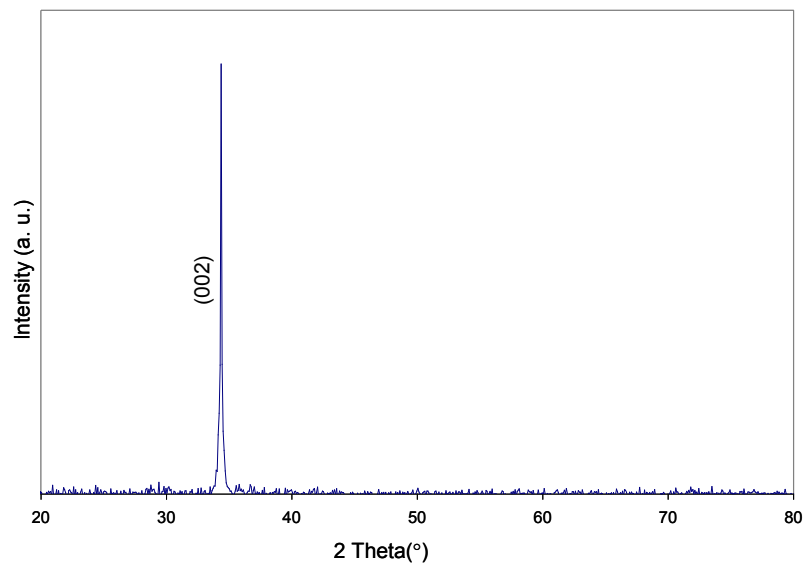

Fig.2 The x-ray diffraction patterns of the $Zn_{0.94}Mg_{0.01}Cr_{0.05}O$ thin film for 10 dip

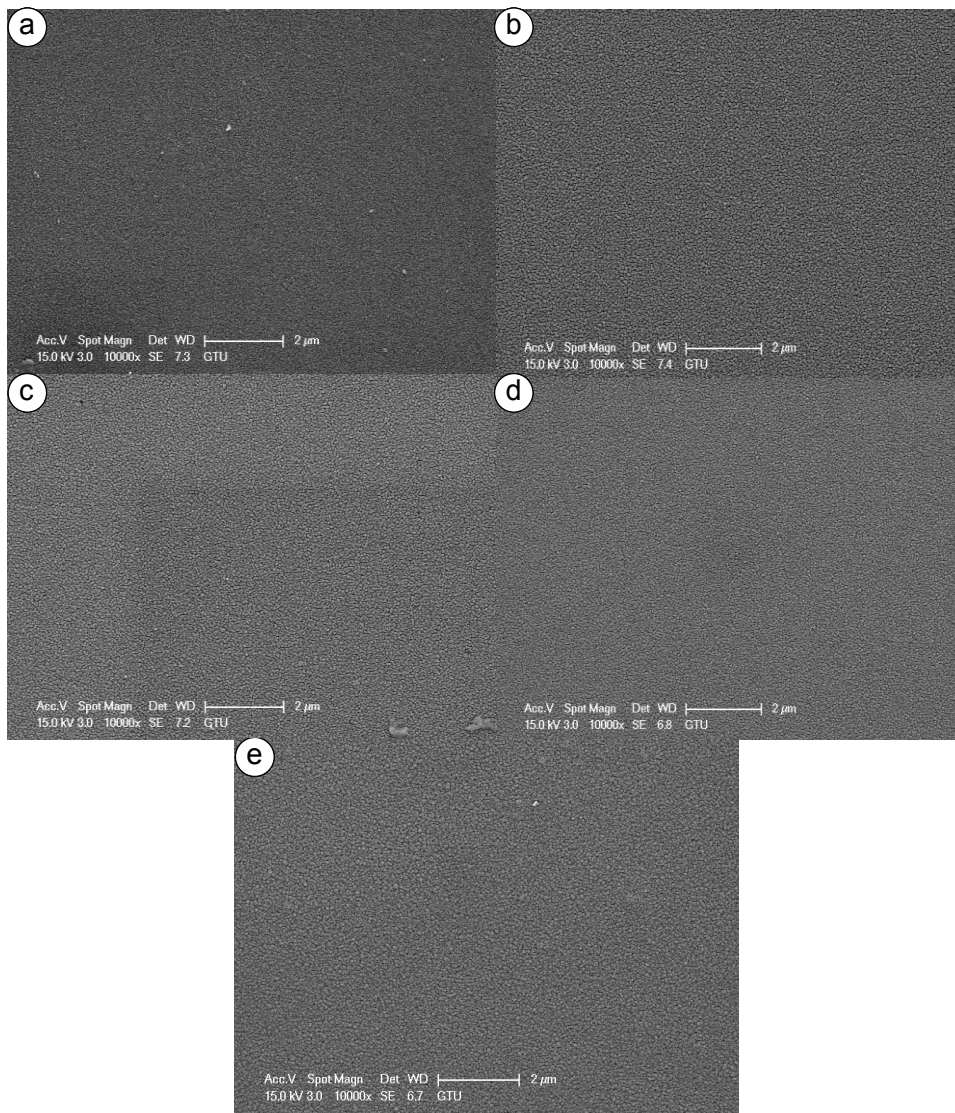

Fig.3 depicts the SEM picture of $Zn_{0.94}Mg_{0.05}Cr_{0.01}O$ thin films a) 10 dips b) 20 dips c) 30 dips d) 40 dip and e) 50 dips.

4. CONCLUSIONS

Zn_{0.94}Mg_{0.05}Cr_{0.01}O thin films were coated by using sol-gel dip coating system. The thickness of the film coating increases by increasing the number of dipping, withdrawal speed, and solution density. Crack and pinhole free and smooth thin sol-gel coating was produced. The thin film was observed uniform on the glass substrate by using SEM.

ACKNOWLEDGEMENTS

The authors would like to thank the Research Fund of Bahcesehir University (BAU-2018) for the supports.

5. REFERENCES

- [1] A. Gungor and L. Arda, 11 th International Research/Expert Conference, "Trends in the Development of Machinery and Associated Technology", TMT (2007), 1543-1546
- [2] A. Gungor, D. Akcan, L. Arda, 18 th International Research/Expert Conference, "Trends in the Development of Machinery and Associated Technology", TMT (2014), 133-136
- [3] L. Arda, D. Akcan, a. Güngör, Journal of Trends in the Development of Machinery and Associated Technology Vol. 19, No. 1, 2015, ISSN 2303-4009 (online), p.p. 61-64
- [4] A. Gungör, D. Akcan, L. Arda, Journal of Trends in the Development of Machinery and Associated Technology Vol. 19, No. 1, 2015, ISSN 2303-4009 (online), p.p. 65-68
- [5] Z. K. Heiba and L. Arda, Structural properties of Zn_{1-x}Mg_xO nanomaterials prepared by sol-gel method", Cryst. Res. Technol. 44, (2009) No. 8, 845-850.
- [6] Z.K. Heiba, L. Arda, XRD, XPS, optical, and Raman investigations of structural changes of nanoCo-doped ZnO, J. Mol. Struct. 1022 (2012), pp. 167-171.